

# Sub 6GHz 5GNR Bands Antenna

## ANT-859-01

### Specifications

Frequency (MHz)	617-798	803-960	1166-1610	1710-2200	2300-2690	3300-3800	4200-5000	5150-5925
Peak gain	1.04 dBi	0.74 dBi	2.31 dBi	3.58 dBi	3.88 dBi	2.26 dBi	4.5 dBi	4.31 dBi
Average gain	-1.96 dBi	-2.54 dBi	-0.82 dBi	-2.05 dBi	-1.41 dBi	-2.23 dBi	-2.51 dBi	-3.03 dBi
Efficiency	46 %	41 %	69 %	65 %	74 %	54 %	60 %	60 %
VSWR	4.0 : 1 Max	4.0 : 1 Max	4.0 : 1 Max	4.0 : 1 Max	4.0 : 1 Max	4.0 : 1 Max	3.0 : 1 Max	3.0 : 1 Max
Polarization	Linear, vertical							
Impedance	50 $\Omega$							
Connector	SMA PLUG							

### Environment & Mechanical Characteristics

Temperature	-40°C to +85°C
Humidity	95% @ 25°C

### VSWR

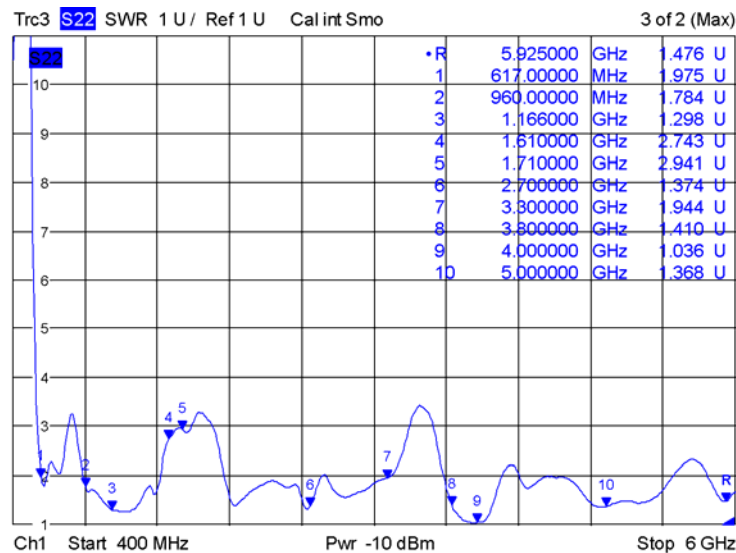

Date: 21.AUG.2020 15:08:14

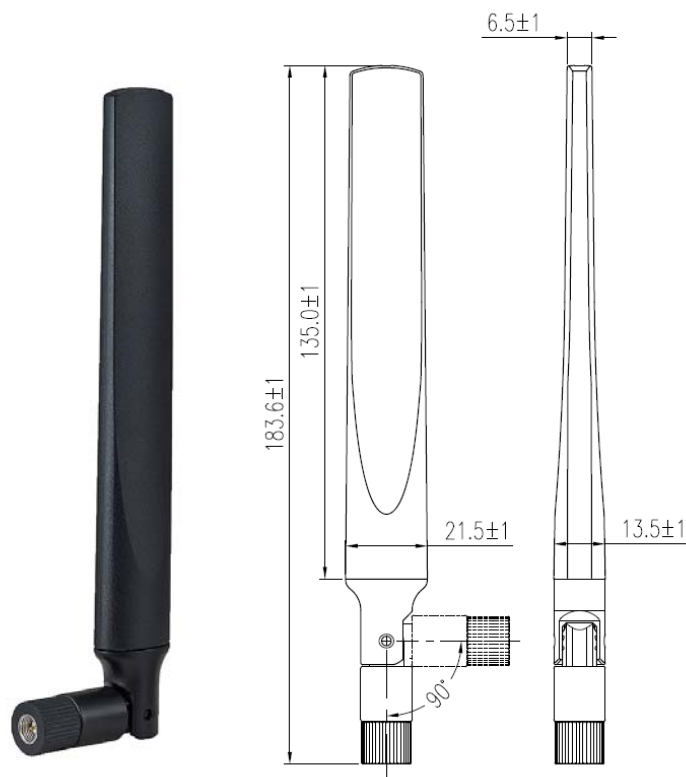

# Radiation Pattern

L1 Band = 650 - 790 MHz % LTE-L Band

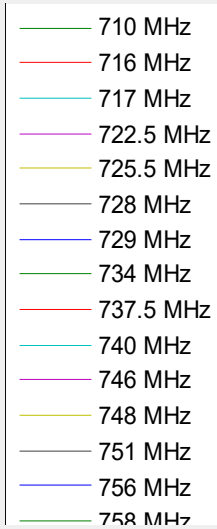

XY Plane (+X = 0°, +Y = +90°) / Elevation = 90 °

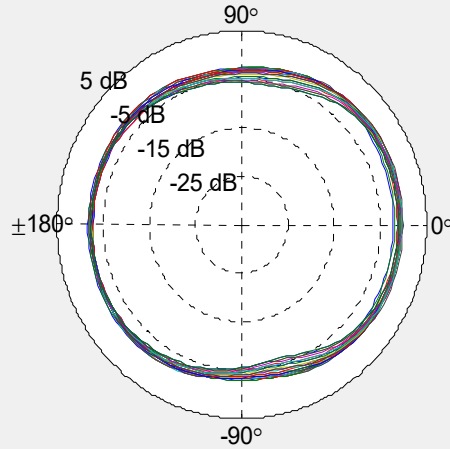

ZX Plane (+Z = 0°, +X = +90°) / Azimuth = 0 °

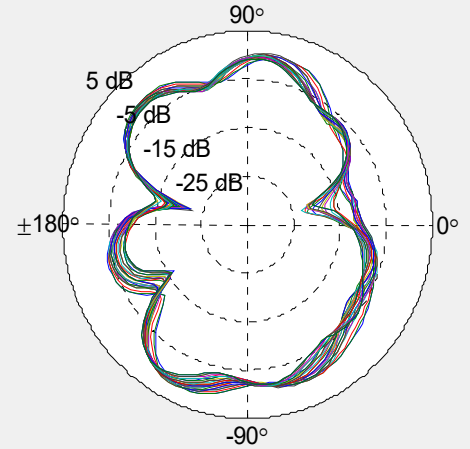

YZ Plane (+Z = 0°, +Y = +90°) / Azimuth = 90 °

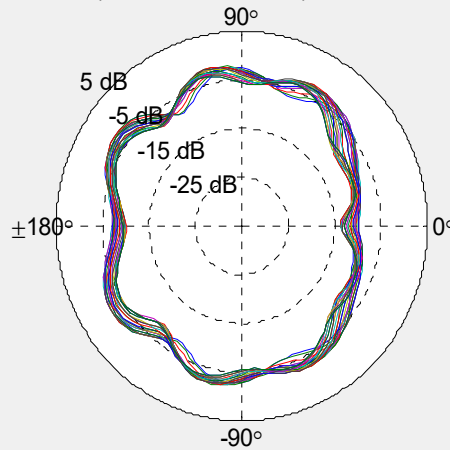

# Radiation Pattern

L2 Band = 791 - 1080 MHz % LTE-L Band

- 830 MHz
- 831.5 MHz
- 832 MHz
- 836.5 MHz
- 837.5 MHz
- 845 MHz
- 847 MHz
- 849 MHz
- 859 MHz
- 860 MHz
- 862 MHz
- 867.5 MHz
- 869 MHz
- 875 MHz
- 876.5 MHz

XY Plane (+X = 0°, +Y = +90°) / Elevation = 90 °

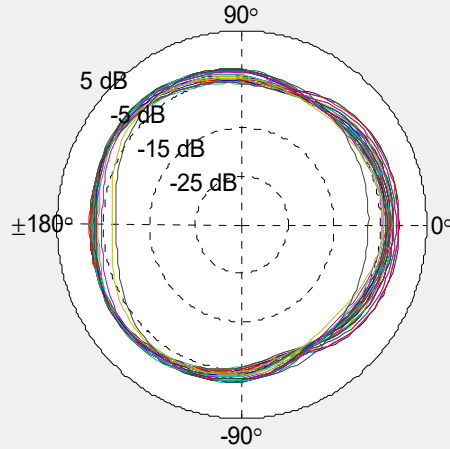

ZX Plane (+Z = 0°, +X = +90°) / Azimuth = 0 °

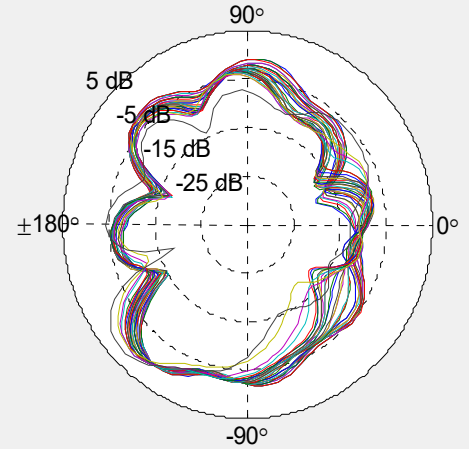

YZ Plane (+Z = 0°, +Y = +90°) / Azimuth = 90 °

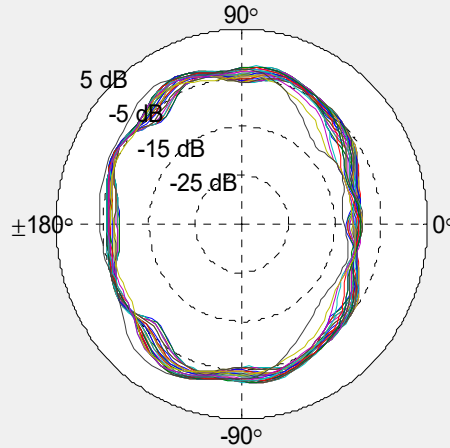

# Radiation Pattern

JP Band = 1400 - 1569 MHz % LTE-JP Band

XY Plane (+X = 0°, +Y = +90°) / Elevation = 90 °

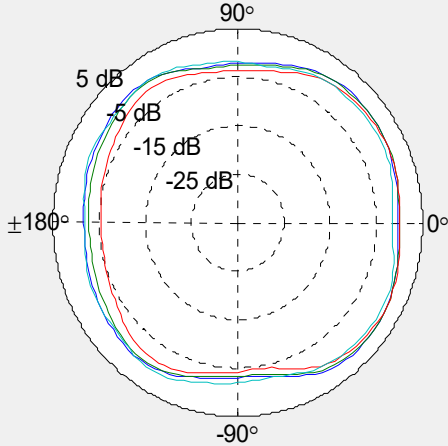

ZX Plane (+Z = 0°, +X = +90°) / Azimuth = 0 °

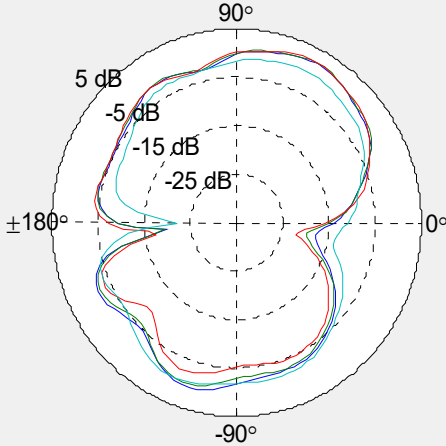

YZ Plane (+Z = 0°, +Y = +90°) / Azimuth = 90 °

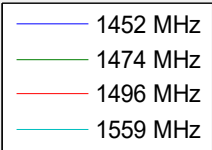
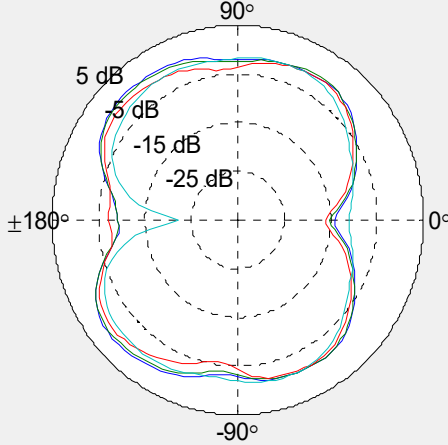

# Radiation Pattern

GPS Band = 1160 - 1680 MHz

XY Plane (+X = 0°, +Y = +90°) / Elevation = 90 °

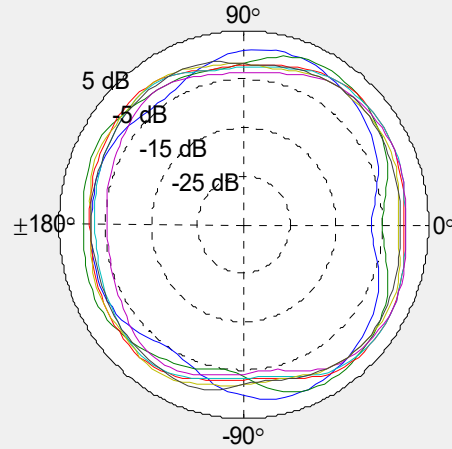

ZX Plane (+Z = 0°, +X = +90°) / Azimuth = 0 °

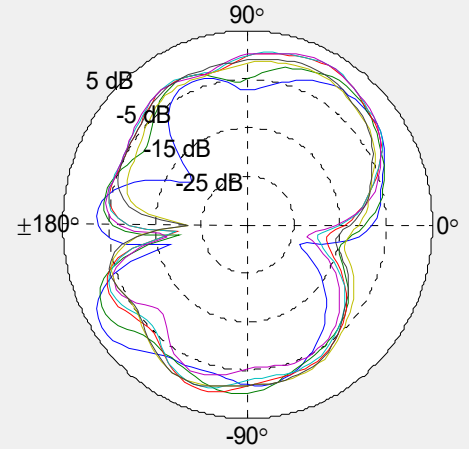

YZ Plane (+Z = 0°, +Y = +90°) / Azimuth = 90 °

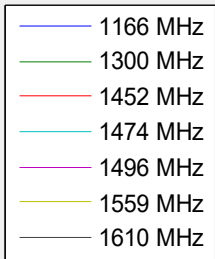
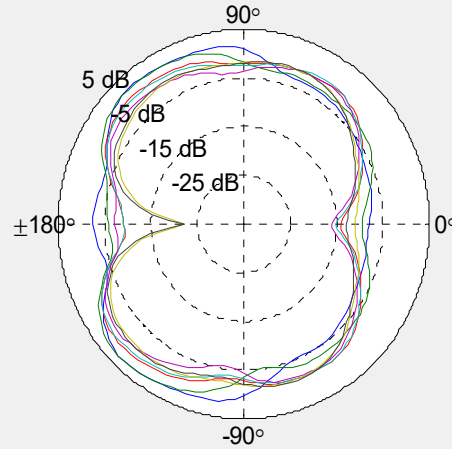

# Radiation Pattern

H1 Band = 1700 - 2000 MHz % LTE-H1 Band

- 1780 MHz
- 1785 MHz
- 1805 MHz
- 1842.5 MHz
- 1850 MHz
- 1880 MHz
- 1880 MHz
- 1882.5 MHz
- 1900 MHz
- 1910 MHz
- 1915 MHz
- 1920 MHz
- 1920 MHz
- 1930 MHz
- 1950 MHz

XY Plane (+X = 0°, +Y = +90°) / Elevation = 90 °

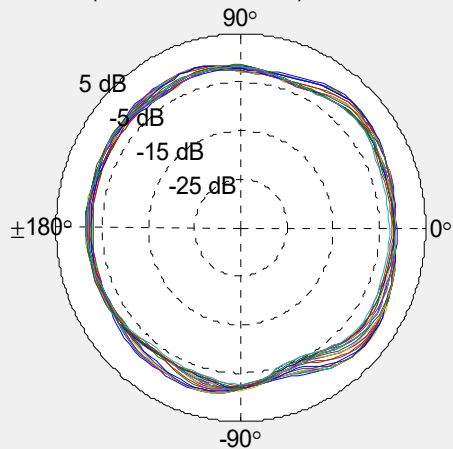

ZX Plane (+Z = 0°, +X = +90°) / Azimuth = 0 °

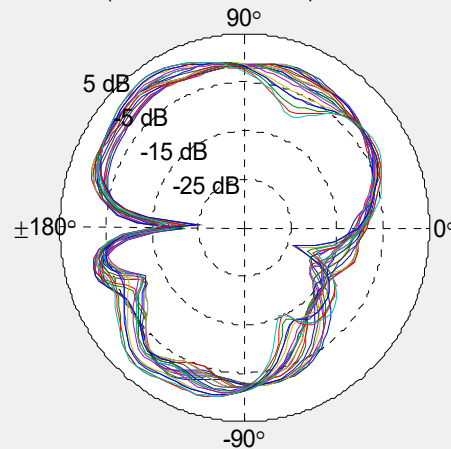

YZ Plane (+Z = 0°, +Y = +90°) / Azimuth = 90 °

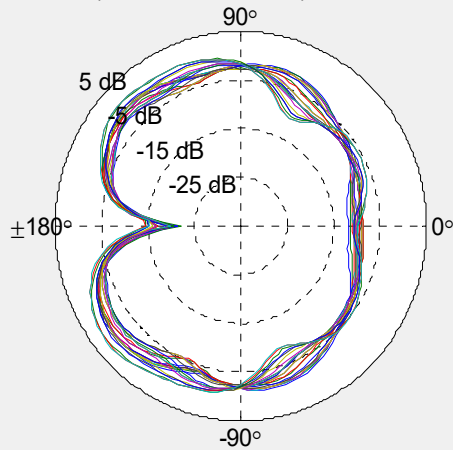

# Radiation Pattern

H2 Band = 2000 - 2200 MHz % LTE-H2 Band

XY Plane (+X = 0°, +Y = +90°) / Elevation = 90 °

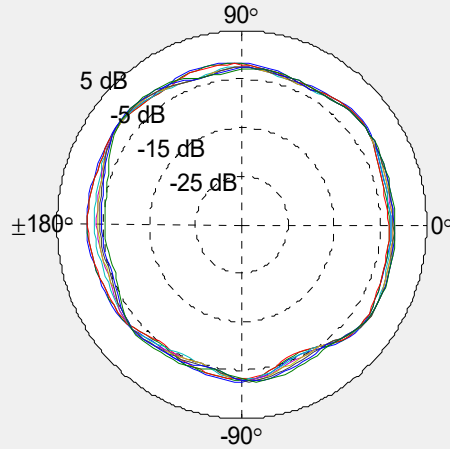

ZX Plane (+Z = 0°, +X = +90°) / Azimuth = 0 °

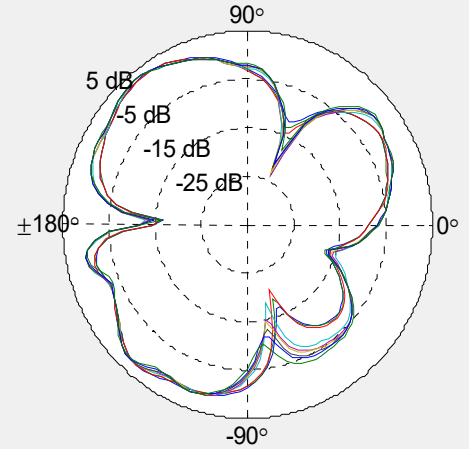

YZ Plane (+Z = 0°, +Y = +90°) / Azimuth = 90 °

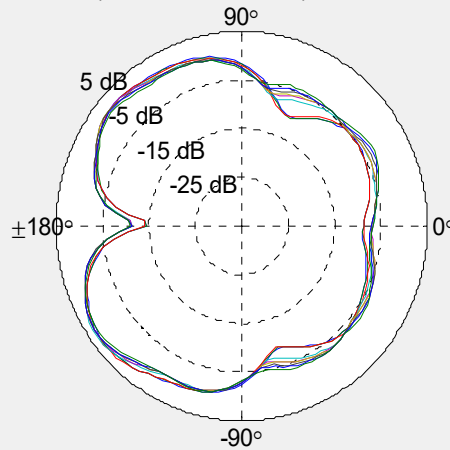

- 2010 MHz
- 2017.5 MHz
- 2025 MHz
- 2110 MHz
- 2132.5 MHz
- 2140 MHz
- 2155 MHz
- 2170 MHz
- 2200 MHz

# Radiation Pattern

H3 Band = 2300 - 2750 MHz

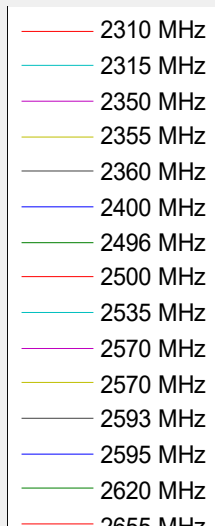

XY Plane (+X = 0°, +Y = +90°) / Elevation = 90 °

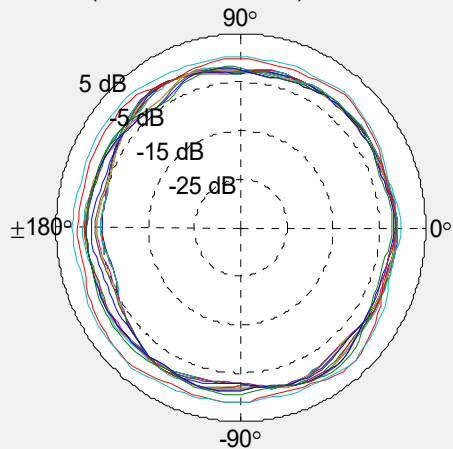

ZX Plane (+Z = 0°, +X = +90°) / Azimuth = 0 °

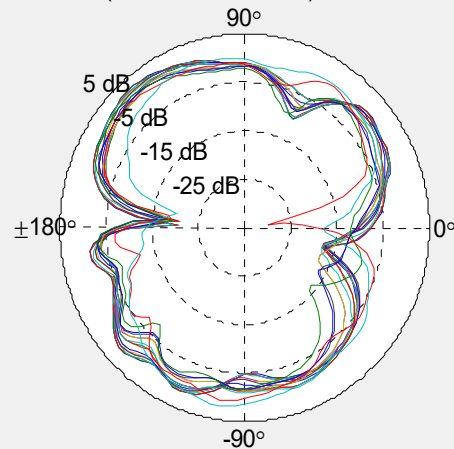

YZ Plane (+Z = 0°, +Y = +90°) / Azimuth = 90 °

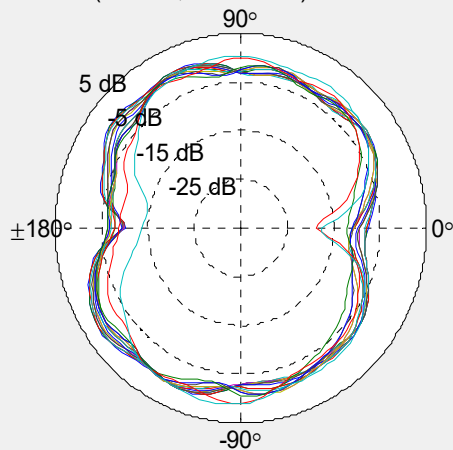



# Radiation Pattern

3G Band = 3000 - 3800 MHz % 3G Band

XY Plane (+X = 0°, +Y = +90°) / Elevation = 90°

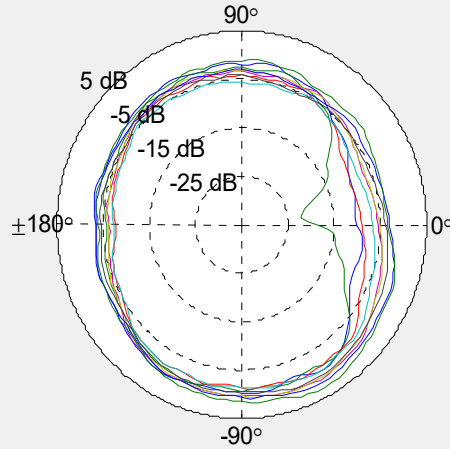

ZX Plane (+Z = 0°, +X = +90°) / Azimuth = 0°

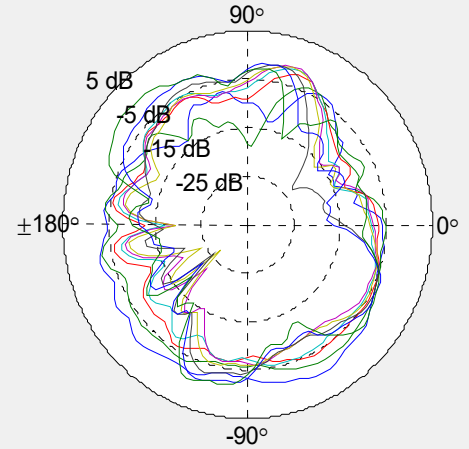

YZ Plane (+Z = 0°, +Y = +90°) / Azimuth = 90°

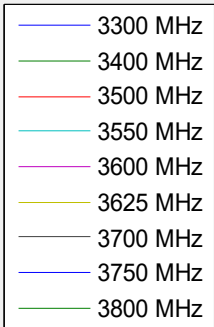
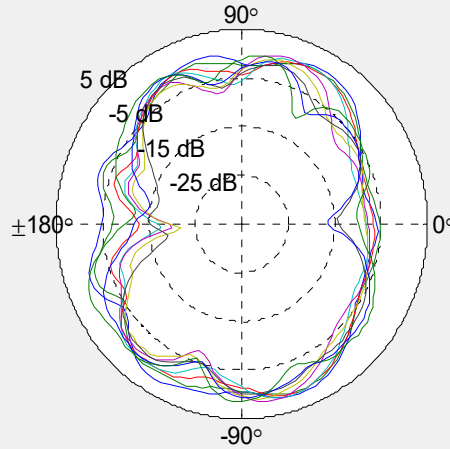

# Radiation Pattern

4G Band = 4200 - 5000 MHz % 5G Band

XY Plane (+X = 0°, +Y = +90°) / Elevation = 90 °

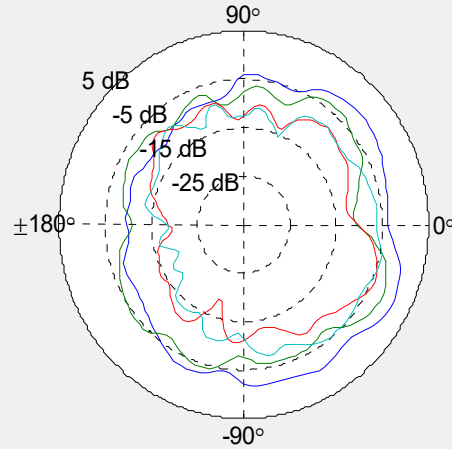

ZX Plane (+Z = 0°, +X = +90°) / Azimuth = 0 °

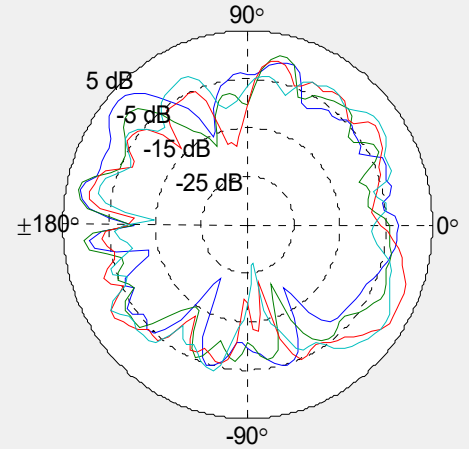

YZ Plane (+Z = 0°, +Y = +90°) / Azimuth = 90 °

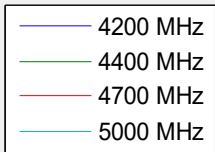
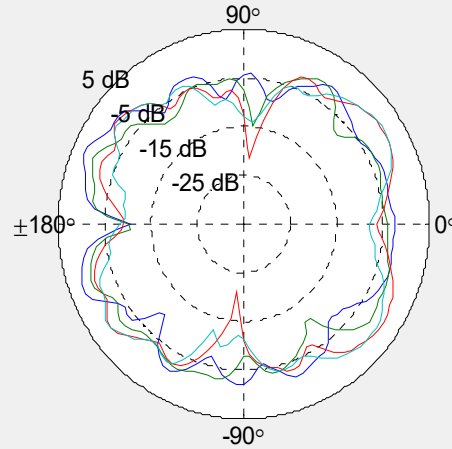

# Radiation Pattern

5G Band = 5150 - 6000 MHz

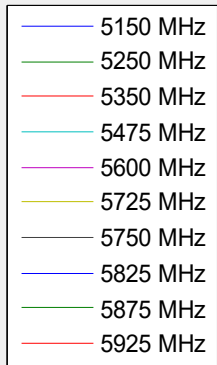

XY Plane (+X = 0°, +Y = +90°) / Elevation = 90 °

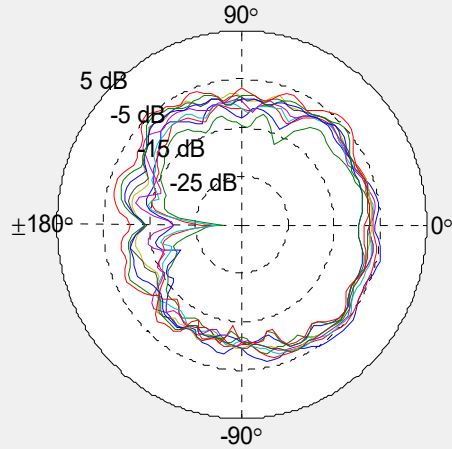

ZX Plane (+Z = 0°, +X = +90°) / Azimuth = 0 °

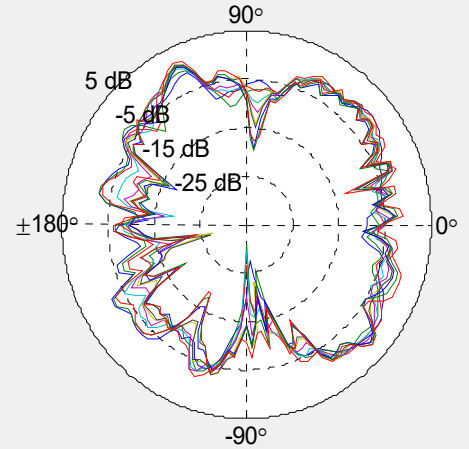

YZ Plane (+Z = 0°, +Y = +90°) / Azimuth = 90 °

